

PLEASE FAX OR MAIL ORDERS TO:

ELECTRICAL SERVICES RENTAL ORDER FORM



62nd Annual Portland Roadsters Show

VENUE: Portland Expo Center

Dates: 03/16/2018 to 03/18/2018

5251 SE McLoughlin Boulevard
Portland, OR 97202-4836

Payment deadline for Pre-Order Discount Rate: 03/02/2018

TEL 503-232-9001 FAX 503-517-8686

To Order Online, go to www.hollywoodlights.biz and use **Event Code: ROADSTERS18**

COMPANY NAME:			BOOTH#(S)
ADDRESS:			BROKER:
CITY:	STATE:	ZIP:	TEL:
ORDERED BY:			FAX:
SIGNATURE:			PAID:

I authorize Hollywood Lights, Inc to debit my credit card for the changes listed below and for any additional charges incurred.

CREDIT CARD #:	CVV#:	EXP. DATE:
CARDHOLDER:	AUTH. SIGNATURE:	

Card holder billing address (if different from above):

And all labor, outlets, lights and tax:

ADDRESS:			TOTAL DUE:
CITY	STATE	ZIP:	WA TAX 0 %:

LABOR: Order labor in 1 hour increments, applies as listed below: Outlet location other than back wall of booth. Cords taped down or run under carpet. Overhead work. (Lift rental may also apply).	Labor Hours	Mon-Fri 8 Am - 5 PM	EVENINGS WEEKENDS	HOLIDAYS	Amount
		\$65	\$97.50	\$130	
		\$65	\$97.50	\$130	

ELECTRICAL SERVICES AND EQUIPMENT	QUANTITY	QUANTITY 24 Hour (double rate)	PRE-ORDER DISCOUNT PRICE	FLOOR ORDER PRICE	AMOUNT
120 VOLT DUPLEX RECEPTACLE					
0 - 600 WATTS / 5 AMPS			\$75	\$94	
601 - 1200 WATTS / 10 AMPS			\$95	\$119	
1201 - 1800 WATTS / 15 AMPS			\$115	\$144	
1801 - 2400 WATTS / 20 AMPS			\$135	\$169	
208 VOLT SINGLE PHASE (Additional labor charges may apply)					
0 - 15 AMP 208 VOLT (includes labor)			\$220	\$275	
16 - 30 AMP 208 VOLT (includes labor)			\$241	\$302	
31 - 50 AMP 208 VOLT (includes labor)			\$355	\$444	
OTHER ___ VOLT ___ AMPS			CALL	CALL	
208 VOLT THREE PHASE (Additional labor charges may apply)					
0 - 15 AMP 208 VOLT (includes labor)			\$250	\$313	
16 - 30 AMP 208 VOLT (includes labor)			\$280	\$350	

	QUANTITY	QUANTITY 24 Hour (double rate)	PRE-ORDER DISCOUNT PRICE	FLOOR ORDER PRICE	AMOUNT
31 - 50 AMP 208 VOLT (includes labor)			\$410	\$513	
OTHER ___ VOLT ___ AMPS			CALL	CALL	
ELECTRICAL ACCESSORY RENTAL					
15 AMP 120 VOLT POWER STRIP			\$18	\$23	
25' 120 VOLT EXTENSION CORD			\$18	\$23	
15 AMP 120 VOLT GFCI WHIP			\$22	\$28	
50 AMP 208 VOLT GFCI (HOT TUB)			\$56	\$70	
50 AMP 208 - 230 VOLT TRANSFORMER			\$60	\$75	
SPOT OR FLOODLIGHTS					
300 WATT FLOOD (___) OR SPOT (___)			\$75	\$94	
500 WATT ARM FLOODLIGHT			\$75	\$94	
1000 WATT SPOTLIGHT (ceiling mount)			\$120	\$150	

Please note: Audio visual equipment does not include a power source. Order outlets on the first page if show is not providing outlets. Audio visual equipment subject to availability and should be ordered in advanced.

Video					
17" LCD Display on table stand			\$300	\$375	
22" LCD Display on table stand			\$360	\$450	
32" LCD Display on table stand			\$540	\$675	
46" LCD Display on table stand			\$900	\$1125	
55" LCD Display on table stand			\$1080	\$1350	
80" LCD Display on floor or table stand			\$2160	\$2700	
65" Plasma Display on table stand			\$1620	\$2025	
AV Cart with Black Skirt - No Display			\$96	\$120	
Floor Stand - No Display			\$180	\$225	
Universal Mount - No Display			\$75	\$93.75	
DVD Player			\$126	\$157.5	
PC Show Computer			\$360	\$450	
Macbook 15"			\$540	\$675	
Brightsign Player			\$150	\$187.5	
DA 1x2 (Link two displays to one source)			\$150	\$187.5	
DA 1x4 (Link four displays to one source)			\$300	\$375	

	QUANTITY	QUANTITY 24 Hour (double rate)	PRE-ORDER DISCOUNT PRICE	FLOOR ORDER PRICE	AMOUNT
HD DVD Player			\$270	\$337.5	
Other			CALL	CALL	
Audio					
10" Full Range Powered Speaker on Tripod Stand			\$150	\$187.5	
12" Full Range Powered Speaker on Tripod Stand			\$270	\$337.5	
18" Sub Powered Speaker			\$270	\$337.5	
4 Channel Mixer			\$180	\$225	
16 Channel Mixer			\$270	\$337.5	
CD Player			\$135	\$168.75	
Wired Hand Held Microphone			\$75	\$93.75	
Wireless Hand Held Microphone			\$360	\$450	
Wireless Lapel or Earset Microphone			\$450	\$562.5	
Table Top Microphone Stand			\$45	\$56.25	
Floor Microphone Straight Stand			\$45	\$56.25	
Floor Microphone Boom Stand			\$75	\$93.75	
Other			CALL	CALL	

GENERAL INFORMATION

Rental Information:

1. Material and equipment provided by this order shall be and shall remain the property of Hollywood Lights, Inc. and shall be removed ONLY by Hollywood Lights personnel at the close of the show.
2. Credit will not be given for service installed as requested in this order even though not used.
3. Exhibitors are not allowed to share power.
4. Outlets are located at the back center of each 10' x 10' booth space. Booths measuring 10' x 20' or larger must order an outlet for each 10' x 10' section if electrical service is required for each.
5. Bulk space and large oversized booth electrical information should be mapped out on drawings to indicate location of outlets. Labor charges apply to these booths.
6. Electrical power is on continually during move in. On show days, power is turned on 30 minutes before show opening and turned off at show closing. If you need power on 24 hours, YOU MUST ORDER 24 HOUR SERVICE. Any exhibitor wishing early turn on or late turn off of electrical to booths, must make special arrangements with the show management and Hollywood Lights, Inc.
7. Wall, column and permanent building utility outlets are not part of your booth space and are not to be used. If services are found to be used which have not been purchased, they will be charged at twice the LATE ORDER rate.
8. Exhibitor holds Hollywood Lights, Inc. harmless for any and all losses of power beyond Hollywood Lights Inc. control, including but not limited to: losses due utility company failure, permanent power distribution failure, power failure caused by vandalism, faulty exhibitor equipment, Exhibitor equipment not compatible with GFCI outlets or overloads caused by exhibitor.
9. All Electrical Equipment must comply with Federal, State and Local Codes, Hollywood Lights, Inc. is required to refuse connection where the exhibitor wiring is not in accordance with electrical codes.

10. CLARK COUNTY WA ONLY

Dept of Labor and Industries Rules: GFCI PROTECTION: Exhibitors must provide GFCI protection at all times when utilizing Power tools and/or electrical features with water: Hot Tubs, sinks, fountains, etc. including during move in/move out. Hollywood Lights has a limited supply of GFCI protection for rent.

11. Electrical Permits are required on all 208 volt and higher services and will be added to your electrical order. Please call for pricing.

Labor Information:.

12. Labor Charges apply to the following:

- A) All 120 volt outlets above 20 amps
- B) Power needed other than back wall
- C) Electrician to tape down cords
- D) Overhead service requests

13. There is a 1 hour minimum labor charge included on all 208- volt orders. Material charges may apply. This includes wiring of our pigtail into your machine or removing your plug and putting ours on. If you require services not posted, please call for a quote.

14. The electricians will not connect any exhibit that does not meet the electrical code. Hollywood Lights, Inc. is not responsible for problems arising from unlabeled, mislabeled and the use of non-standard wiring practices on equipment.

Payment Information:.

15. Orders must be received with payment by the pre-order deadline date to receive discounted rate. All other orders will be charged the Standard Rate. Orders received without payment will not be processed. Orders received after the preorder deadline date will be charged as a late order. Phone orders cannot be accepted.

16. Charges for electrical services must be paid prior to the opening of the show (in US funds) EXHIBITORS are not billed for services provided. (Power will be disconnected for non payment.)

ALL DISCREPANCIES MUST BE SETTLED BEFORE CLOSE OF SHOW

LIGHTING INFORMATION

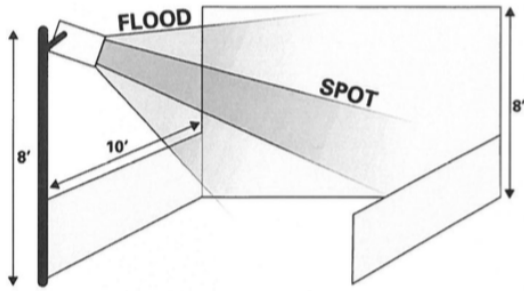

300-WATT FLOOD LIGHT OR SPOT LIGHT MOUNTS ON 8-FOOT UPRIGHT AT FRONT CORNER OF BOOTH.

500-WATT FLOOD LIGHT ATTACHES TO BACK WALL AND EXTENDS OUT OVER BOOTH #. THIS IS OUR MOST POPULAR LIGHT.

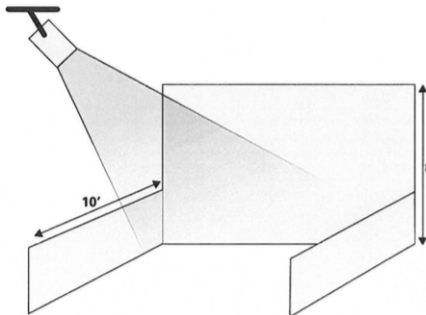
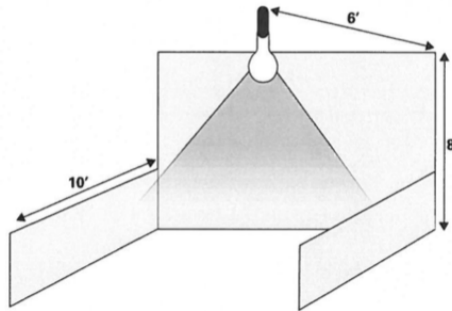

500-WATT AND 1000-WATT QUARTZ SPOTLIGHT INSTALLED OVERHEAD IN CEILING. THESE UNITS WORK WELL FOR LIGHTING SPECIFIC MACHINERY.